

DATA LOGGER FOR ULTRA SONIC FLAW DETECTOR

RDSO Specification: M&C/NDT/115/2000

Data logger for ultra sonic flaw detector is used to log the details of flaws scanned by the single or double rail testers with respect to the physical location. The logged data can be uploaded into PC, and generate different types of reports.

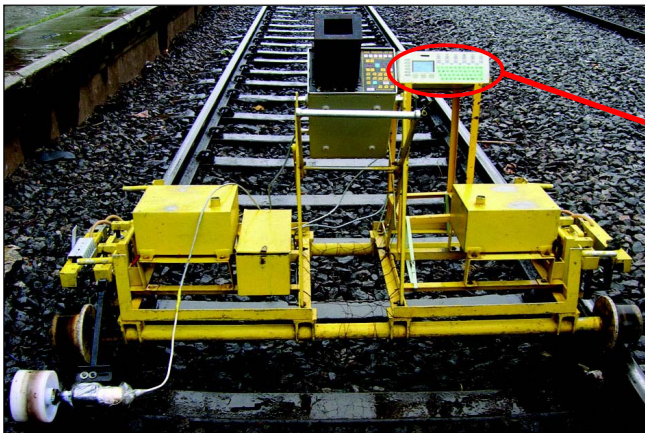
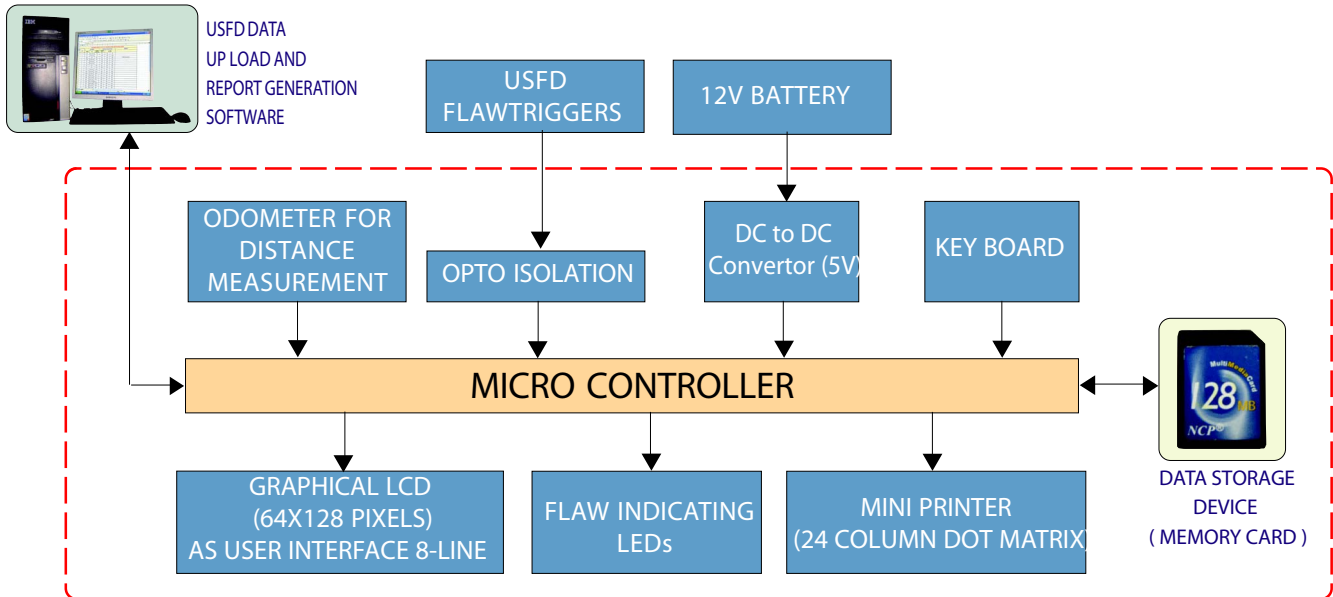

RAIL TESTER

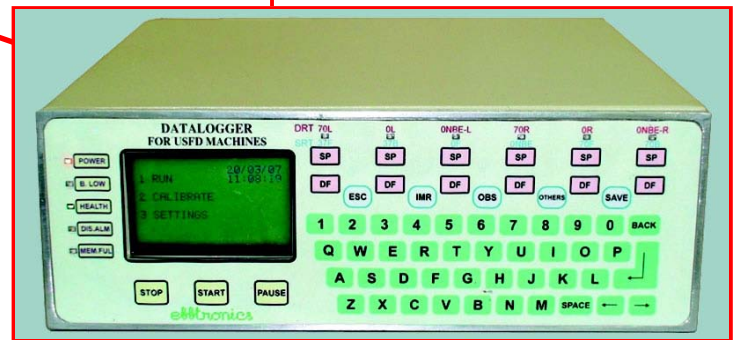

USFD DATALOGGER

- Interface to Ultrasonic Single or Double Rail tester (SRT/DRT)
- Logs the data with time and distance on occurrence of flaw.
- 6 Nos. of Flaw Channels.
- Data storage in removable memory card.
- Odometer for measuring the distance.
- LCD, Keyboard and Mini Printer for user interface.
- Serial port for data upload to PC.
- Report software for MIS.
- About 200Km field trial on Vijayawada Division Successfully Completed.